

ELEVATION VIEW

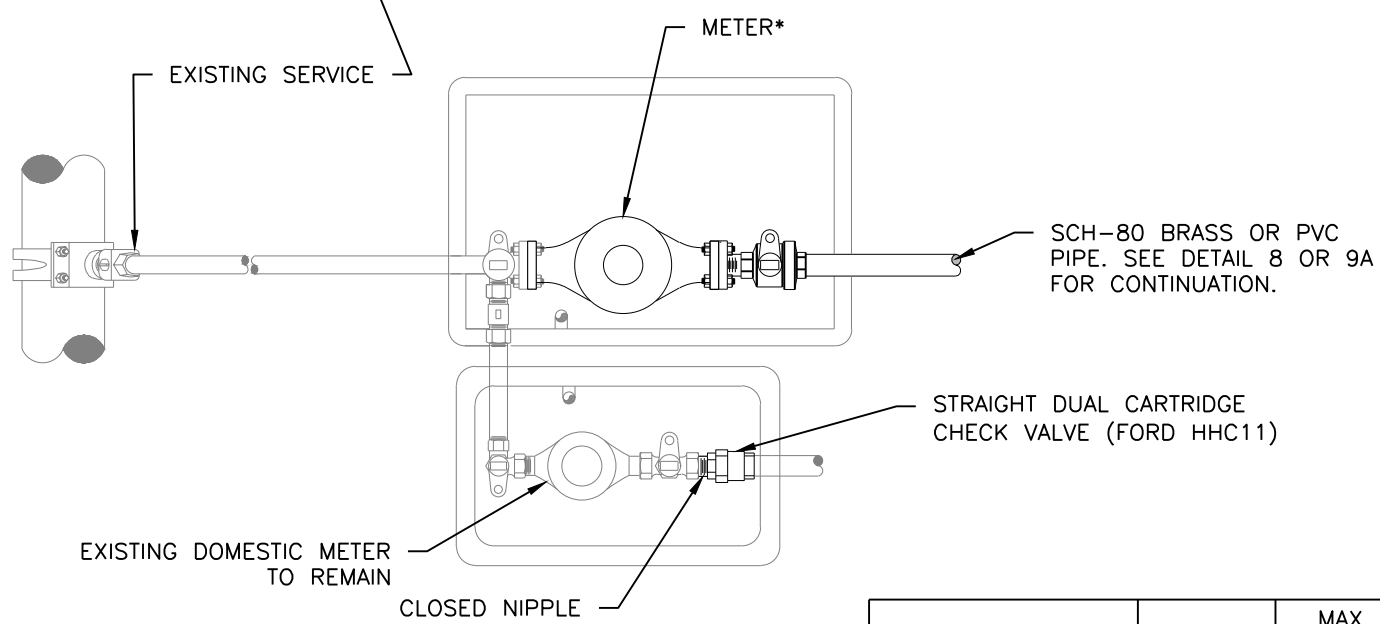

PLAN VIEW

METER SIZE	METER LENGTH	MAX. FLOW RATE (GPM)
¾" THREADED	7 ¾"	30
1" THREADED	11"	50
1 ½" FLANGED	13 ¼"	100
2" FLANGED	17"	160

NOTES

- * FIRE SERVICE METER AND FIRE SERVICE BFD TO BE SIZED BY OTHERS
- 1. METER FLANGES, ADAPTERS GASKET, BRASS NIPPLES AND STAINLESS STEEL NUTS AND BOLTS AS NEEDED TO COMPLETE RETROFIT, FORD METER BOX COMPANY OR APPROVED EQUAL.
- 2. BRASS FITTINGS, VALVES AND PIPE SHALL CONSIST OF LOW-LEAD BRASS ALLOY AND SHALL HAVE A MINIMUM WORKING PRESSURE OF 150 PSI.
- 3. FIRE SERVICE LINE SHALL BE TESTED FOR LEAKS PRIOR TO BACKFILLING.
- 4. CUSTOMER SIDE FIRE SERVICE PIPE TYPE AND CONNECTION SHALL MEET LOCAL FIRE AGENCY REQUIREMENTS.
- 5. ALL FITTINGS BETWEEN DISTRICT METER AND BACKFLOW DEVICE SHALL BE NSF 61 CERTIFIED MATERIAL.

SCOTTS VALLEY WATER DISTRICT
WWW.SVWD.ORG

DETAIL 4 RETROFIT
COMBINATION FIRE AND DOMESTIC
SERVICE RETROFIT

NOT TO SCALE